

PT Series

Instructions for use and maintenance



Ed. 2009



Via Ugo Foscolo, 1
21040 Venegono Superiore
Varese (Italy)

DICHIARAZIONE DI CONFORMITÀ CE
DECLARATION OF CONFORMITY CE



Machines manufactured for:
Bracton Industries (NSW) Pty Ltd.
www.bracton.com
enquiries@bracton.com

Noi dichiariamo sotto la nostra esclusiva responsabilità che il prodotto:
The undersigned hereby declares under full responsibility that the following product:

DISHWASHING MACHINE

PT Series ...,

al quale questa dichiarazione si riferisce, è conforme alle seguenti norme:
for which this declaration refers to in accordance to the following standards:

EN 60335-1, EN 60335-2-58, EN 61000-3-2, EN 61000-3-3, EN 55014-1, EN 55014-2

in base a quanto previsto dalle Direttive CEE:
on the basis of what is foreseen by the Directives CEE:

2006/95/CE (LVD) – 2006/108/CE (EMC)

Decliniamo ogni responsabilità per sinistri a persone o a cose derivanti da manomissione da parte di terzi o da carenza di manutenzione o riparazione.
We decline any responsibility for injuries or damage derived from machine misuse, abuse by others or improper machine maintenance or repairs.

26/11/2009

(Data emissione)
(Date of issue)

Giuseppe RIENZI
DELEGATO ALLA SICUREZZA DEL PRODOTTO

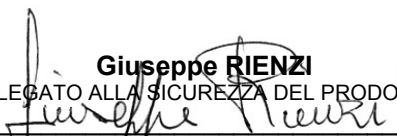
(Nome e firma o timbratura equivalente della persona autorizzata)
(Name signature or equivalent of authorized representative)

Dishwashing machine

PT Series

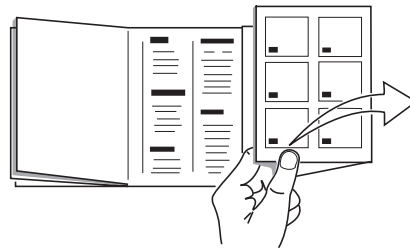

The illustrations concerning these instructions are on the inside of the back cover

ENG

IMPORTANT

Become thoroughly familiar with the contents of this manual before installing, setting up, adjusting and servicing dishwasher machine.

Only contact an Bracton authorise technical center or Bracton on (02) 9938 1800 in the event of breakdowns or faulty machine operation.

The manufacturer reserves the right to modify the products whenever necessary, without affecting their main features.

INDEX

Important pag. 4

Overall dimensions pag. 6

Technical data pag. 7

Description of the controls pag. 8

Bracton
Leaders through innovation and design

OVERALL DIMENSIONS

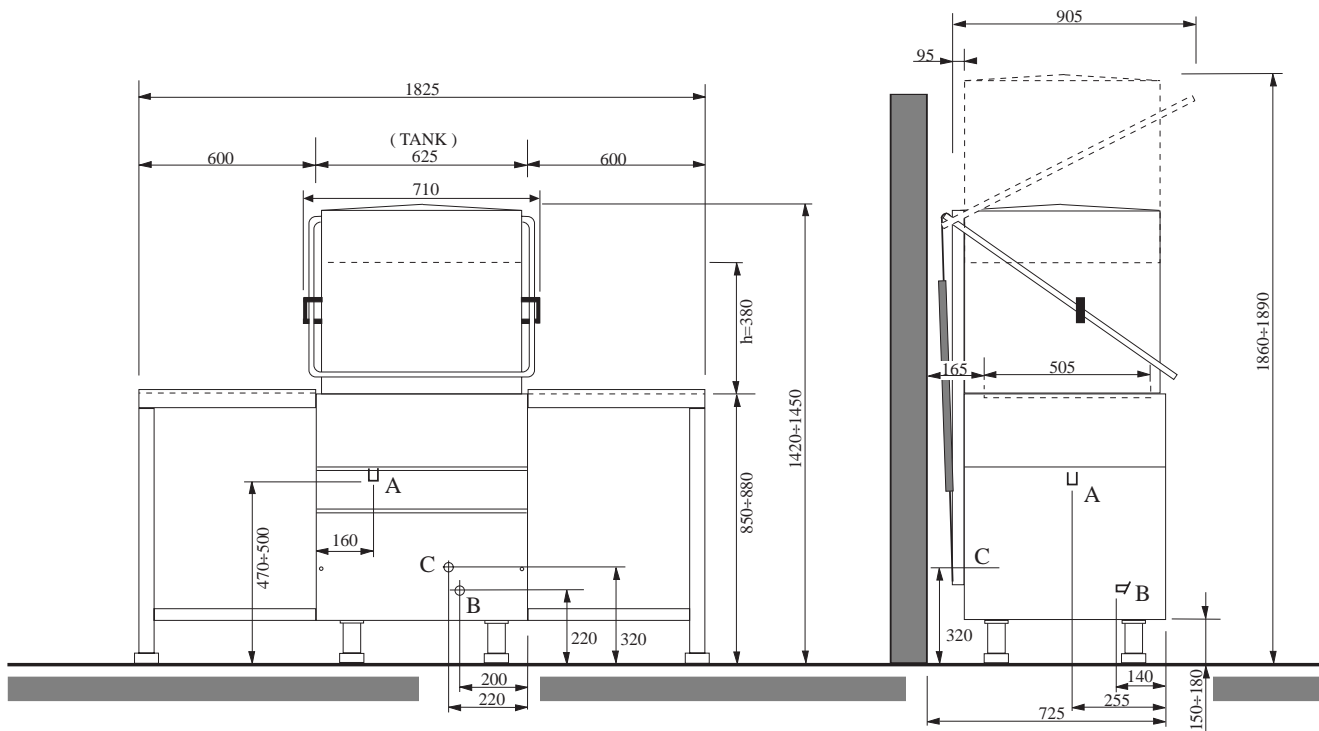

A: Drain pipe fitting - **B:** Water inlet - **C:** Electric supply

TECHNICAL DATA

	Baskets output p/h	Electric supply	Total power	Boiler heating element	Tank heating element	Wash pump
PT Series	60/30/20	400V3 N-50 Hz	6750 W	6000 W	3000 W	750 W
	Tank capacity	Boiler capacity	Mains supply of water	Water consumption cycle	Cycle length	Basket dimensions
PT Series	48 l	8,2 l	2÷ 4 bar. Ø 3/4" G.	3,5 l	60/120/180 s	500 x 500 mm
	Drain pipe fitting	Net weight	Gross weight	Environmental temperature min/max.	Environmental humidity min/max	Wash temperature
PT Series	Ø 1" G	99 kg	120 kg	5° ÷ 40° C	20 ÷ 90 %	50° ÷ 60° C
	Rinse temperature	Noise level				
PT Series	82° C	< 70 dB (A)				

CONTROL PANEL

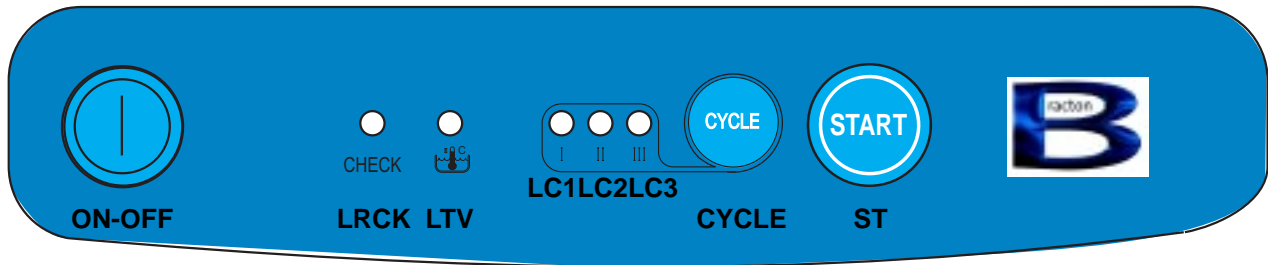

Fig. 1

LEGEND

ON-OFF)	Line button ON/OFF
LRCK)	CHECK led light (green)
LTV)	Tank temperature led light (green)
LC1)	SHORT cycle led light (green)
LC2)	MEDIUM cycle led light (green)
LC3)	LONG cycle led light (green)
CYCLE)	CYCLE selection button
ST)	START CYCLE button

ENGLISH

Part 1: General description and safety device

Part 2: For the Operator

**Part 3: For Authorised and Qualified
Technicians**

ENGLISH

PARTICULAR RECOMMENDATIONS FOR THE OPERATOR

- Do not operate the machine without having become fully familiar with the contents of this manual and without having acquired a comprehensive knowledge of the specific techniques and machine controls.
- Check that the area in which the machine is to be installed is compatible with the dimensions of the machine itself before installing this latter.
- Only use lifting and handling means that are suited to the weight of the machine when this must be installed or removed either completely or in part.
- Never allow unauthorised or unqualified personnel to start, adjust, operate or repair the machine. Always refer to this manual for correct operation.
- **Always ensure that the main switch has been set to the "OFF" position before cleaning and/or servicing the machine.** This will disconnect the power source during the operator's intervention.
- The electrical powering system must be equipped with an automatic release system prior to the main machine switch and with a suitable grounding system that complies with all the requisites established by industrial provisions for the prevention of accidents.
- Always disconnect the power source if work must be carried out on the main switch or in its vicinity.
- All inspections and maintenance operations requiring removal of the safety guards are carried out under the complete responsibility of the users. These operations should therefore only be carried out by specialised and authorised technical personnel.
- Make sure that none of the accident preventing safety devices (barriers, guards, casings, microswitches, etc.) have been tampered with and that they are all perfectly functional before operating. These devices should be repaired if this is not the case.
- **Never remove the safety devices.**
- To prevent personal risks, only use power tools that are correctly connected to the grounding tap and that conform to the national safety regulations.
- Never ever tamper with the electrical system or with any other mechanism.
- **Never ever use the hands** or unsuitable instruments to locate leaks from pipes. Air, fluids under pressure or irritants could cause serious damage to both persons and/or property.
- Never use the hands instead of adequate tools when operating the machine.
- Never use the hands or other objects to stop moving parts.
- **PAY THE UTMOST ATTENTION TO THE DATA PLATES AFFIXED TO THE MACHINE WHENEVER WORKING ON THIS OR IN THEIR NEAR VICINITY.**
- The user is obliged to keep all the data plates and stickers in a legible condition.
- Never climb on to the door or on to the top of the machine.
- It is essential for the user to replace all data plates and stickers that may have deteriorated for any reason or that are not clearly visible, ordering new ones from the Spares Service.
- Contact the person in charge of maintenance in the event of malfunctions or damage to the machine components without proceeding with further repairs.
- It is absolutely forbidden for anyone to use the machine for purposes other than those explicitly established and documented. The machine must always be used in the ways, times and places dictated by common sense and the laws in force in each country, even when there are no specific provisions to govern the sector in the particular country of use.
- **The manufacturer and distributor declines all responsibility for accidents or damage to either persons or property as may arise following failure to comply with either the relative safety provisions or the instructions herein.**
- **These instructions, together with the provisions governing machine installation and electrical connections form an integral part of the Accident Preventing Industrial regulations in force in each individual country.**
- **THESE SAFETY PROVISIONS INTEGRATE AND DO NOT SUBSTITUTE THE SAFETY PROVISIONS LOCALLY IN FORCE.**
- **NEVER ever make hurried or inaccurate repairs that could jeopardise the correct operation of the machine.**
- **ALWAYS ASK FOR HELP FROM SPECIALISED PERSONNEL IN CASE OF DOUBT.**
- **ANY TAMPERING BY THE USER RELIEVES THE MANUFACTURER FROM ALL LIABILITY, THE USER BEING IN THIS CASE SOLELY RESPONSIBLE TOWARDS THE COMPETENT ACCIDENT PREVENTION AUTHORITIES.**

1.1 PT Series GENERAL DESCRIPTION

Passthrough dishwasher hood type for linear or angle setup made entirely in AISI 304 stainless steel, with adjustable feet.

The hood is easily raised thanks to the large handle and system of balancing springs that minimise the effort required from the operator. Stainless steel wash arms designed to exert maximum pressure, optimising the wash for all types of dishes, plates etc.

The dishwasher can be supplied with various tabling solutions to suit customer's requirements.

1.2 TYPE OF USE AND IMPROPER USE

These machines have been designed and built to wash crockery placed in special baskets and using detergent and rinsing agent.

- Permitted crockery: glasses, teacups, trays, coffee cups, saucers, cutlery made of materials suitable for dishwashers and of a size able to fit into the basket and machine.
- Use of specific detergents and rinsing agents for industrial purposes normally available in the shops is permitted.



ATTENTION

Any improper use of the machine relieves the manufacturer from all and every responsibility for accidents or damage to persons and property, also voiding all conditions of guarantee.

1.3 TRANSPORT, SHIPMENT AND STORAGE (Fig. 2)

- The machine is normally shipped in a cardboard box closed by straps.
- When transporting the packed machine, use a lift truck or transpallet, positioning the box on the relative forks.



ATTENTION

The machine must be sheltered from the weather when shipped and stored.

1.4 INSPECTIONS ON ARRIVAL

When the machine arrives, check that the packaging is in a perfect condition and that there is no visible damage.

If everything is in order, remove the packaging (unless other instructions have been received from the manufacturer) and check that the machine is free from damage caused by transport.

Now check whether there has been any damage to the structure, crushing or breakages.

If damage or imperfections are discovered:

- 1 - Immediately notify the haulage contractor both by phone and in writing by registered letter with return receipt attached;
- 2 - Inform the manufacturer by registered letter (with return receipt attached).

IMPORTANT

Notification of damage or faults must be immediate, in any case **within 3 days** from the date on which the machine is received.

1.5 UNPACKING (Figs 2-3-)

Proceed in the following way in order to remove the packing:

1. Cut the straps (10) that hold the cardboard in place.
2. Remove the box (11) by lifting it upwards.
3. Remove the protective film from the machine.
4. Remove the machine from the base by lifting it from the lower part of the casing.
5. All packing must be collected and not left within children's reach since it could become a source of danger. The packing can be disposed of in the same way as solid urban waste.

Lift the machine by raising the lower part of the casing using a lift truck or transpallet.

1.6 MACHINE IDENTIFICATION (Fig. 4)

- The serial number and machine data are stamped on the data plate (12) affixed to the rear part of the machine itself.

IMPORTANT

Always state the model and serial number of the machine when requesting technical assistance or ordering spare parts.

1.7 DESCRIPTION OF THE SAFETY DEVICES

- Models **PT Series** are equipped with a safety microswitch that blocks the washing pump if the tub access door is accidentally opened, and of other electronic safety devices.
- The electrical parts are enclosed by panels locked by screws.
- The machine is fitted with an equipotential ground conductor.
- Safety overflow to prevent water from spilling.

1.8 REFERENCE STANDARD

- The machine and its safety devices has been built in compliance with the following standards:
- Essential safety requisites established by Directive 2006/95/CE (LVD) and 2006/108/CE (EMC).
- Essential requisites established by Directive 2002/95/EEC (RoHS).

2.1 WASHING PHASES PT Series

2.1.a Switching on and Preparing the machine

To switch on the machine, press the power switch (IL) into the ON position.

The LED indicating the last cycle selected will become CONSTANTLY LIT (LC1, LC2 or LC3), as will the CHECK (LRCK) LED and the tank temperature LED (LTV) (all green).

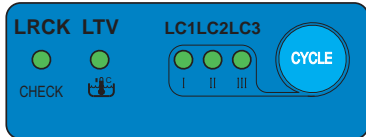

IMPORTANT

On first switching on, LED LC2 will light up.

The boiler, and then the tank, will start to fill automatically.

Once the water level has been reached, the heating elements will switch in, first in the boiler, then in the tank.

Once the water in the tank reaches the correct temperature, the tank temperature LED (LTV) will go ON.

IMPORTANT

Open the door and pour the detergent directly into the tank, in the quantities recommended by the manufacturer; this operation should not be carried out if the machine is equipped with a dosing pump (optional).

WASHING OPERATION

If not equipped with an automatic dosing system, pour into the tank a quantity of detergent suitable for the volume and hardness of the water. For quantities, refer to the specific instructions for the detergent in use.

ATTENTION

When items to be washed are encrusted with burnt on matter, or a long time has passed between use and washing, it is essential to carry out a pre-wash soak using a suitable softening agent. The use of hand-washing products is to be avoided as they could produce foam inside the machine.

Place the basket of items to be washed inside the machine, having first removed any solid waste.

2.1.b Selecting a Cycle

The duration of the washing cycle can be chosen from three different lengths of time (SHORT, MEDIUM, LONG), to be selected using the "CYCLE" button. Each time the "CYCLE" button is pressed, the blue LEDs (LC1, LC2 or LC3), will light up or go out in sequence as shown in the following table:

LC 1:	SHORT CYCLE	= 60 sec.
LC 2:	MEDIUM CYCLE	= 120 sec.
LC 3:	LONG CYCLE	= 180 sec.

2.1.c AUTOMATIC and MANUAL STARTING WASHING CYCLE

The washing cycle starting can be performed in two different ways: AUTOMATICALLY (by closing the door) or manually (by pressing START (ST) button).

The change the modality press and hold "CYCLE" button for 10 sec.

When CYCLE LED flashes slowly, the cycle start AUTOMATICALLY; when CYCLE LED is lit fixed, the cycle start MANUALLY.

2.1.d STARTING the WASHING CYCLE

To start the washing cycle, close the hood (or press and hold the START (ST) button for a few seconds, then release).

Throughout the washing cycle the LED(s) for the selected cycle (LC1, LC2 or LC3) will FLASH.

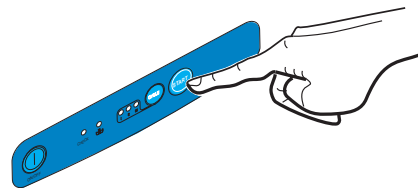

ATTENTION

We recommend that you top up the detergent used up by washing grease or dispersed during rinsing every 4-5 complete cycles.

The use of the machine ensures rinsing at the ideal temperature for hygienic purposes every time; Indeed, if the temperature is not sufficient the wash will be automatically prolonged so as to ensure the necessary conditions of optimum rinsing at 82°C.

The waiting time required to attain optimum temperature can extend to a maximum of 8 minutes.

While this is taking place, the CHECK LED will FLASH RAPIDLY until the end of the cycle. To reset the flashing, switch the machine off and back on using the power switch (IL).

Add a spoonful of detergent to the tank every 5/6 washes;

Dosages given are by way of indication only, and should be adjusted according to the hardness of the water and the type of detergent used.

IMPORTANT

Between cycles it is advisable to keep the door closed so as to prevent the water in the tank from cooling.

2.1.e Interrupting the cycle

1) It is possible to interrupt the washing cycle momentarily by opening the door, this is an EMERGENCY measure:

the cycle LEDs (LC1, LC2 or LC3) will start to FLASH, alternating with the CHECK LED.

On closing the door, operations will resume from the point in which they stopped.

2) The cycle can also be interrupted by SWITCHING the machine's power switch (IL) to the OFF position.

3) On switching the machine back on, the LED indicating the last cycle selected will light up.

At the end of the washing cycle, take out the basket and shake it gently so as to remove the last drops left on the washed items.

Allow items to dry and remove them from the basket with clean hands.

Store all items on hygienic and completely stable surfaces.

2.1.f Manual Draining

It is possible to drain the water from the tank at any time during the day, according to the waste accumulated.

To carry out this operation, proceed as follows:

- SWITCH the machine's power switch (IL) to the OFF position and release the overflow, allowing all the water to drain from the tank;
- Remove the tank filters (25/27) and clean;

Manual draining for machines with drainage pump

For machines fitted with a drainage pump it is possible to empty the tank by carrying out the manual draining cycle, during which only the drainage pump remains active.

IMPORTANT

This cycle can only be carried out by leaving the machine SWITCHED ON with the tank full of water and the door OPEN.

Having released the overflow, press and hold the START (ST) button until the LED LC2 and CHECK together) begins to FLASH, and then release the START (ST) button;

The DRAINAGE CYCLE will begin.

IMPORTANT

By pressing the START (ST) button or switching the power switch (IL) to OFF, you can interrupt the drainage cycle before the preset time is up; to restart the interrupted cycle, press START (ST) again.

When the LC2 LED lights up CONSTANTLY, the drainage cycle is finished.

At the end of the cycle, restore the filters (25/27) and the overflow (26) to their respective positions.

2.1.g Switching off at the end of the day

At the end of the working day SWITCH OFF the machine by pressing the power switch (IL) into the OFF position.

Switch off the mains switch feeding the machine and close the water supply taps.

For any repairs, contact only assistance centres authorised by the manufacturer.

2.1.h Warnings during the operation

1) Ensure that the washing temperature remains at approx. 55-60°C;

2) Avoid immersing bare hands in the detergent-filled water; if this should happen, rinse immediately and thoroughly with running water;

3) Use only anti-foaming detergents specific for use in industrial machines;

4) Deactivate the machine in case of breakdown or malfunction.

For any repairs, contact only assistance centres authorised by the manufacturer, and insist on the use of original parts.

Failure to follow the above warnings may compromise the safety of the washing machine.

2.1.i Useful advice for better washing results

Any unsatisfactory results from washing can be seen when traces of dirt are left on dishes or other items;

any water marks may be caused by insufficient rinsing.

In this case, ensure that the rinsing nozzles (31) are clean and that there is pressure in the water system.

If there are traces of waste, ensure that:

- The filters (25/27) are clean;
- the water temperature is around 60°C;
- items are correctly positioned in the basket;
- the washing/rinsing nozzles are clean;
- the arms (28/29) rotate freely.

2.2. CLEANING (Fig. 7)

2.2.a General information

Strict compliance with the maintenance instructions in this section will keep your machine in a good working condition and will notably reduce the need for repairs.



If any machine component becomes faulty, **FIRST CHECK** that all the instructions given in the previous paragraphs have been complied with during use.

Repairs must be carried out immediately, as soon as the fault occurs. This will prevent the trouble from becoming worse and damaging other parts.

2.2.b Daily cleaning (Fig. 7)



Daily operations to carry out when work has ended, with the machine off, the main circuit-breaker disconnected, the water cocks off and the washing tub empty.

1. Lift the overflow pipe (26) to completely drain the water from the tub.
2. Remove the filters (25) on top of the tank.
3. Thoroughly clean the inside parts of the machine.
4. Remove the pump safety filter (27).
5. Wash the filter under running water and fit them correctly back in their housings.



Never ever clean the outside parts of the machine with jets of water.

Never use corrosive or acid cleaning products, wire wool or steel brushes since these could damage the machine.

2.3. PREVENTION MAINTENANCE (Fig. 7)



The preventive maintenance operations must be carried out with the machine off, the main circuit-breaker disconnected, the water delivery cocks off and the washing tub empty.

2.3.a Checking and cleaning the spray arms and nozzles (Fig. 7)

Periodically check to make sure that the spray arm (28), the rinsing arm (29) and the relative nozzles are not clogged.

Cleaning the unit:

1. Unscrew the ring nut (30) and lift the spray arms (28) and (29).
2. Wash the washing and rinsing spray arms.
Clean the nozzles if they are clogged and then fit the parts exactly back in their original positions.
3. Remount all parts by complying with the above instructions in reverse.

2.4. DESCALING

Where hard water is present lime scale deposits will form in the machine and on dishes, which must, for reasons of hygiene, be removed by descaling.

Advice on operation procedures and frequency for this treatment are generally given by the detergent supplier, who can provide suitable products.

In order to avoid damaging the machine, do not exceed recommended doses, follow the detergent producer's directions scrupulously and, having finished operations, rinse thoroughly

2.5. TEMPORARY STOPPAGE

If the machine is to be left inactive for a period of some weeks, it is advisable beforehand to load the tank and run a few empty cycles with clean water then drain, so as to avoid the formation of unpleasant odours.

If necessary, repeat the process several times until the water is still clean after washing.

If the stoppage is to be very long, it is advisable to drain the water from the boiler and from the electric pump.

2.6. DEMOLITION and DISPOSAL.



When the machine is to be scrapped, drain the water from the tank and from the boiler, as indicated in the points above, and disconnect the machine from the water and electricity supply networks, then dispose of the components according to current regulations, respecting national and local ecological and environmental legislation, and taking care to separate the parts as follows:

- metallic parts: body work, surfaces, panels, filters;
- electrical parts: motors, remote switches, micro-switches, cabling;
- plastic parts: connectors, baskets;
- rubber parts: tubes, couplings

The producer declines all responsibility for any printing errors contained in this booklet.

The instructions, drawings, tables and everything else in this manual are of a confidential technical nature. For this reason, none of the information may be either completely or partially duplicated or disclosed to third parties without prior written authorisation from HOONVED which is the sole proprietor and which reserves the right to make any modifications as may be considered necessary without advance warning.

SUMMARY TABLE of CYCLE LED CHECK SIGNALS (LRCK)

MACHINE STATUS	CYCLE LED CHECK
Machine OFF	OFF
Machine on line but STAND/BY	ON CONSTANT
CYCLE: washing, pause, rinsing	ON CONSTANT
ALARM: lack of heating	RAPID flashing
ALARM: door open	RAPID flashing
Manual drain	RAPID flashing

TROUBLESHOOTING

PROBLEMS	CAUSES	SOLUTIONS
The machine fails to turn on.	Main switch disconnected.	Turn on the switch.
The machine does not fill with water.	Water cock shut. Dirty fill pipe filter. Rinsing nozzle clogged. Overflow pipe not well connected.	Turn on the cock. Detach the fill pipe (15 Fig. 6) and clean the filter (17). Unscrew and clean the nozzles (31 Fig. 7) under running water. Check the right connection of the overflow pipe (26 Fig. 7)
Insufficient washing.	Wrong pump rotation direction. Clogged washing nozzles. Dirty washing filter. Clogged washing blade.	Call the technician to reverse 2 of the 3 wires on the main switch. Clean the washing blade (28 Fig. 7). Clean the filter (27 Fig. 7). Remove and clean the blade (28 Fig. 7)
Insufficient rinse.	Insufficient washing conditions. Clogged rinsing nozzles. Clogged boiler by limestone. Low main pressure (less than 2 bar. - 200 Kpa). Insufficient temperature. Bad location of the nozzles or damaged nozzles.	Check the correct washing phase. Unscrew and clean the nozzles (31Fig. 7) under running water. Call after-sales service. Wait pressure recovery or purchase a new pressure pump. Call after-sales service. Check the right location of the nozzles and replace damaged ones.

3.1 INSTALLATION (Fig. 5)

- After having removed the packing, check that the machine is in a perfect condition and that all the parts have been included.
- Position the machine in the required setting and level it by means of the feet (13).

3.1.a Drain pipe connection (Fig. 5)

- Connect one end of the drain pipe to the overflow (14) and the other to an already prepared drain trap.

IMPORTANT

It is essential to ensure that the drain pipe runs along the floor and that it is not throttled in any part.

3.1.b Connection to the water main (Figs. 5-6)

- Connect one end of the supplied inlet pipe (15) to the solenoid valve and the other end (15) to a 3/4" hot water supply (50°C), ensure operating water pressure is between 200-400 kpa.

ATTENTION

It is essential to connect the water delivery pipe to a throttle cock in order to separate the water main from the machine itself. Also check that there are no sharp bends.

If there is sand in the water main, it will be necessary to install a filter between the water main and the machine. If the water main is without, it is advisable to install a decalcifier prior to the machine with a setting of min. 4 and max. 8 French degrees.

The manufacturer declines all responsibility for damage to the machines caused by failure to comply with the above listed provisions.

3.1.c Electrical connection (Fig. 5-6)

DANGER

- **Before connecting to the electricity main, always check that the data pertaining to the power source correspond to those indicated on the identification plate (pos. 12 Fig. 4) and that the main electric power switch installed prior to the machine is disconnected "0" OFF.**
- **An appropriately sized omnipolar circuit-breaker with a minimum 3 mm gap between its contacts must be installed between the power supply main and the machine.**
- **The manufacturer declines all responsibility for accidents or damage to persons or property caused by failure to comply with the above listed provisions.**
- Connect the electrical power cable (18) to the main switch installed prior to the machine.
- Connect the equipotential ground conductor to the terminal (19).

This Page
Intentionally
Left Blank

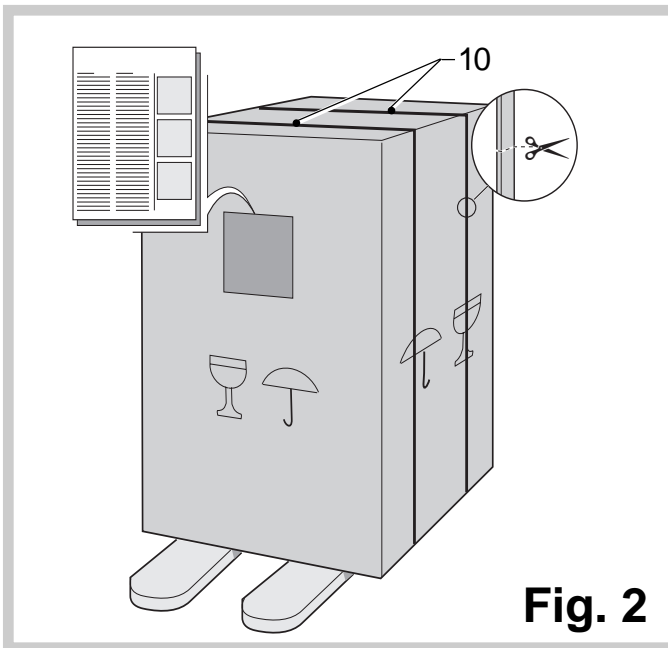

Fig. 2

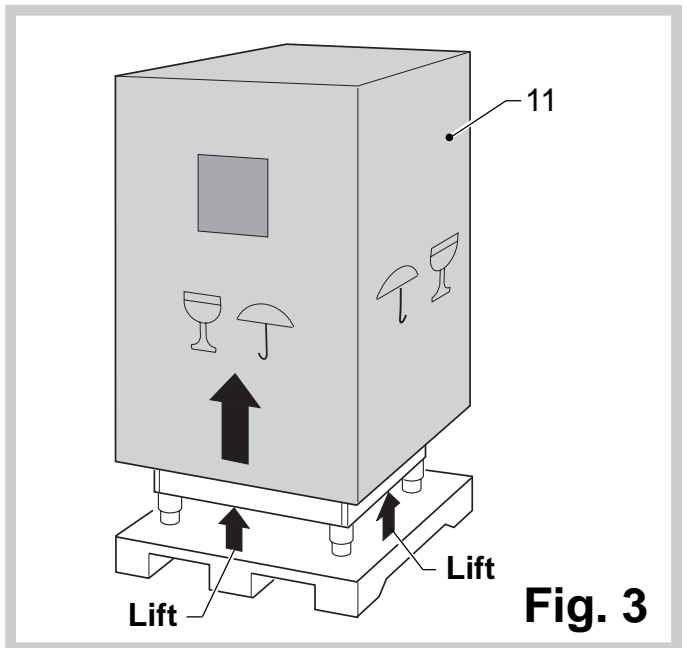

Fig. 3

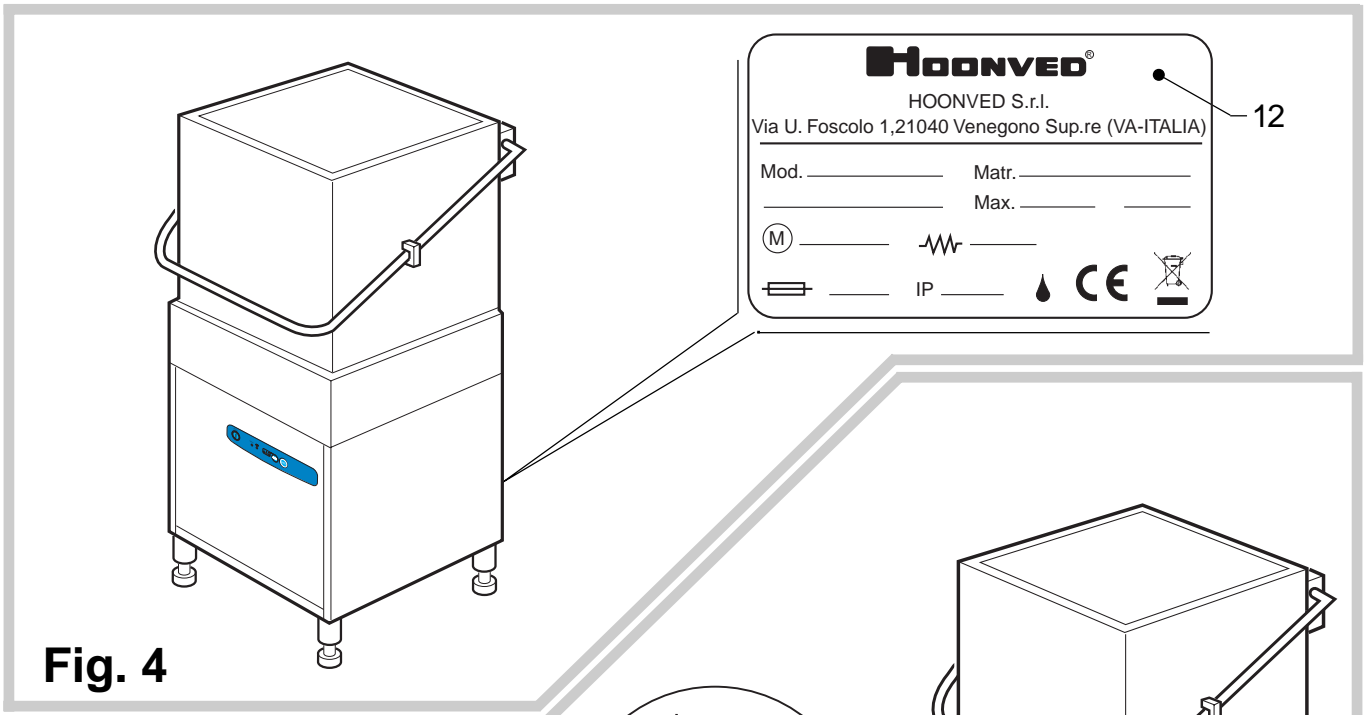

Fig. 4

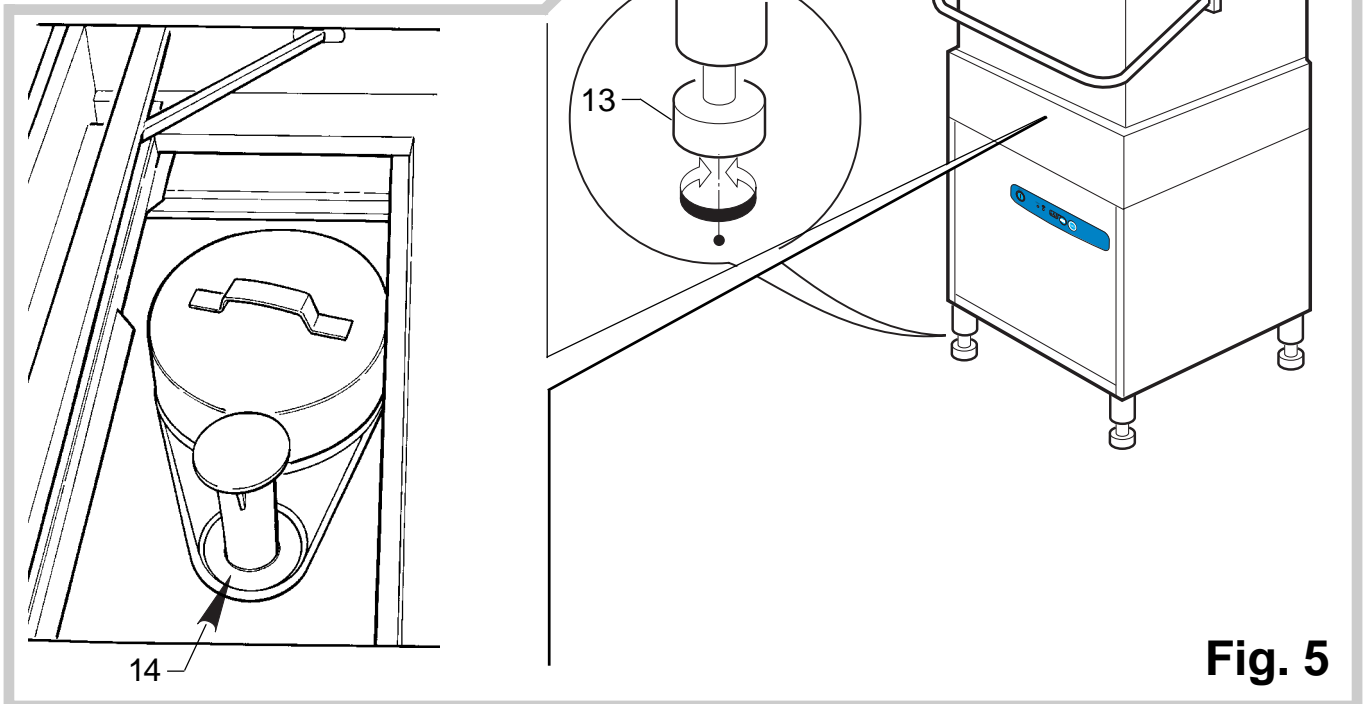

Fig. 5

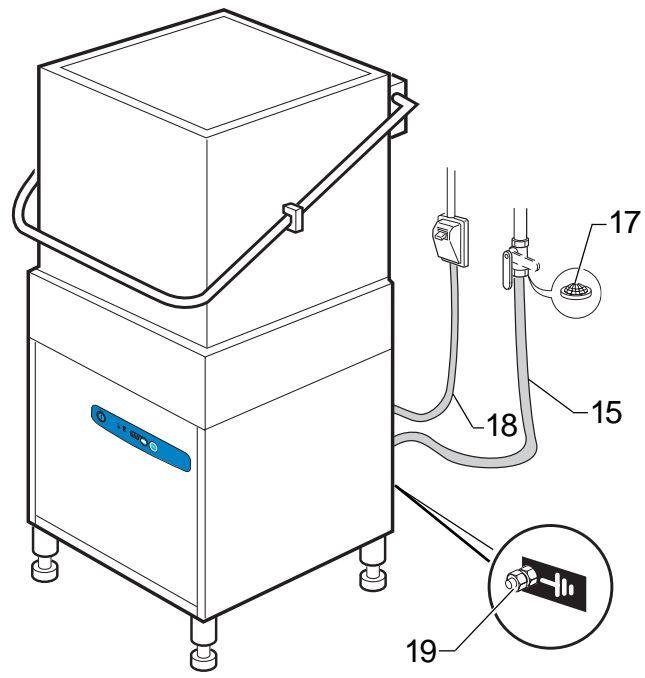

Fig. 6

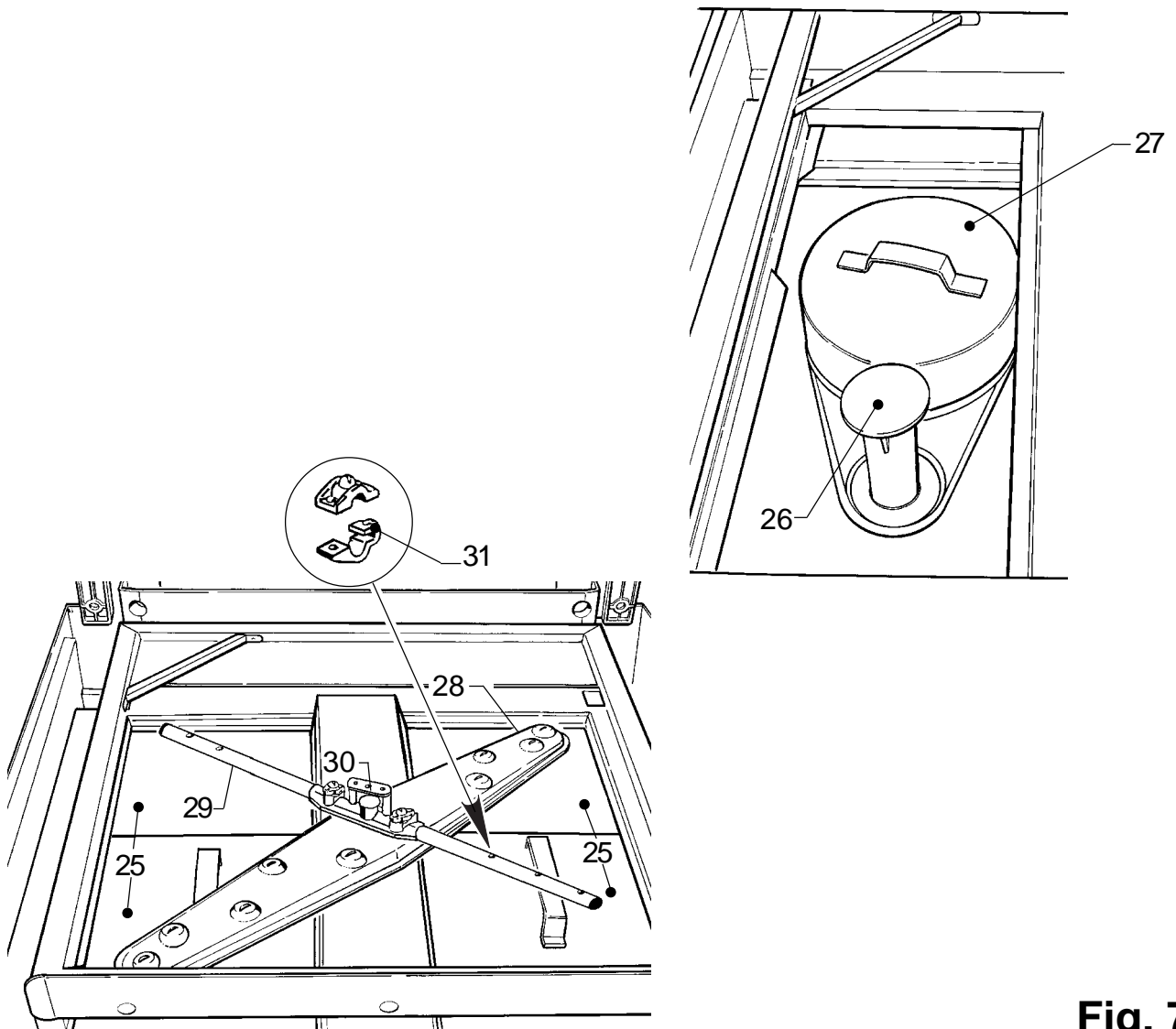

Fig. 7

ELECTRIC DIAGRAM

400V/3N~ 50 HZ

ELECTRICAL DIAGRAM

Ed. 11/2007

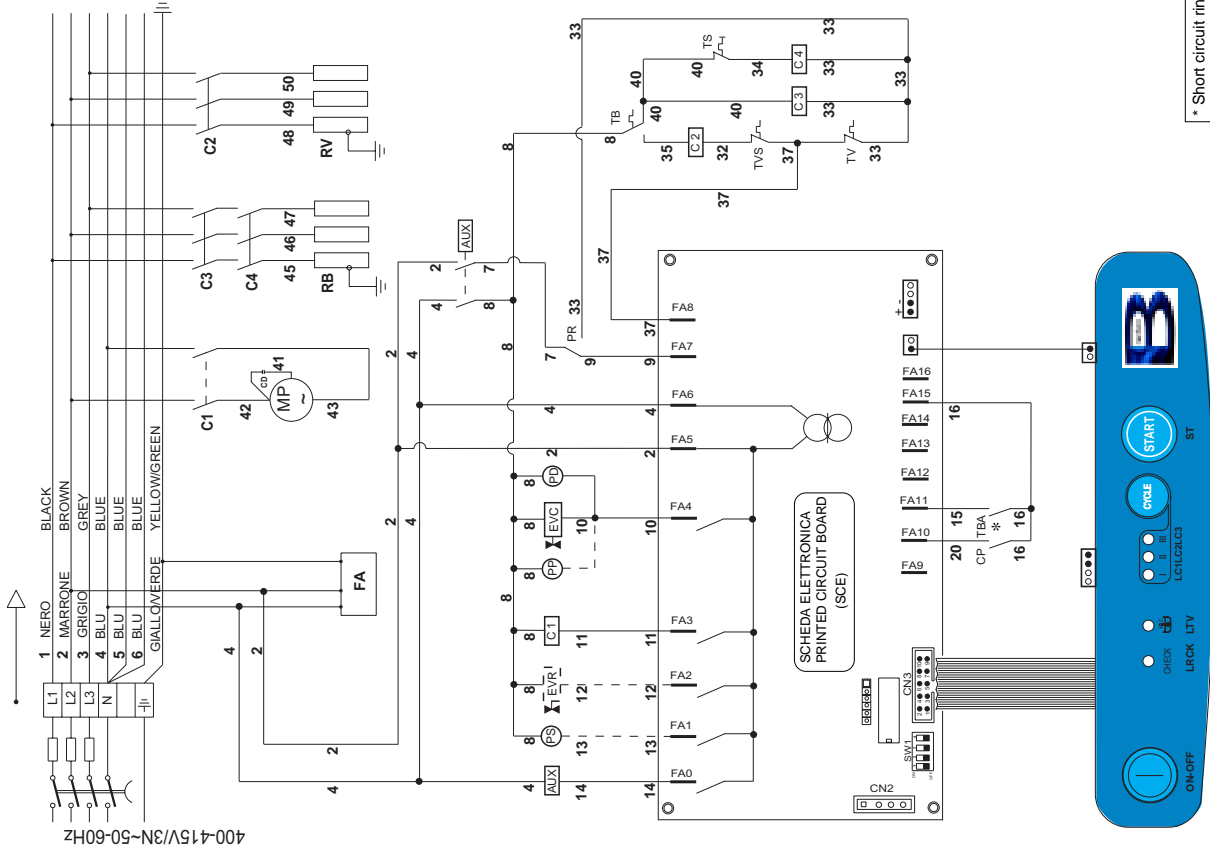

LEGENDA

- ST START button
- PR Pressure
- LC1 COURT cycle light
- LC2 MEDIUM cycle light
- LC3 SHORT cycle light
- LTV Tank temp. light
- LRCK CHECK alarm led light
- CP Door contact
- TB Boiler thermostat
- TV Tank thermostat
- TS Bipolar safety thermostat
- TVS Tank thermostat with manual resetting
- RB Boiler heating el.
- RV Tank heating el.
- EVC Solenoid valve
- MP Wash pump
- FA Anti-noising filter
- C1 Pump contactor
- C2 Tank heating el. contactor
- C3 Boiler contactor
- C4 Boiler safety contactor
- AUX Auxiliary contactor
- PS Drain pump (optional)
- PP Pression pump (optional)
- CD Condensator
- PD Detergent pump
- SCE Printed circuit board
- TBA Auxiliary boiler thermostat

* Short circuit rinse check, Rinse check deactivated.

37777

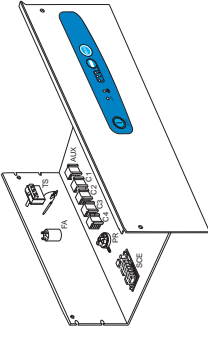

TIMES DIAGRAM

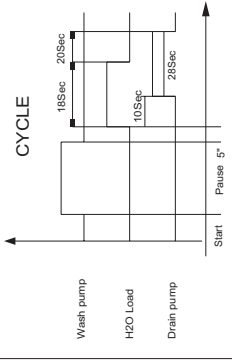

*see instruction for use

Boiler thermostat connection

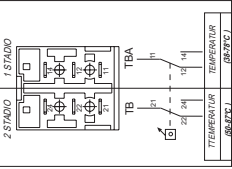

DIP-SWITCH FUNCTION TABLE 1/2

DIP	FUNCTION
DIP 1	START NORMAL WASHING CYCLE
DIP 2	START SEQUENZIAL WASHING CYCLE
DIP 3	REGENERATION DISABLE
DIP 4	REGENERATION ABLE

CYCLE SELECTION TABLE

DIP 3	LC1	LC2	LC3
ON	short cycle	medium cycle	long cycle
ON	60 sec.	120 sec.	180 sec.
OFF	120 sec.	180 sec.	240 sec.

RINSE TIME SELECTION

DIP 4	RINSE TIME
ON	23 sec.
OFF	18 sec.

This Page
Intentionally
Left Blank

This Page
Intentionally
Left Blank

Manufactured by:

HOONVED s.r.l.

Via U. Foscolo, 21040 - Venegono S. (VA) - ITALY

Tel. 0331 - 856111 - Fax. 0331 - 865223

www.hoonved.com

For:

Bracton Industries (NSW) Pty Ltd - leaders through innovation & design

50 Chard Rd, Brookvale NSW Australia 2100

TEL: 02 9938 1800 -- FAX: 02 9905 0979

www.bracton.com sales@bracton.com